

FEATURES

Full evaluation kit for the ADM1073 hot swap controller

Kit contains two boards:

- Main evaluation board for bench evaluation

- Micro evaluation board to drop into user's system

Both boards feature:

- On-board FET to control load current

- Programmable current limit levels (value of R_{SENSE})

- Programmable operating voltage range ($R1-R4$ resistors)

- Choice of default or custom timing values

- LEDs on all logic inputs and outputs

- Pushbuttons for asserting logic inputs

Main evaluation board features:

- Banana connectors for connecting power and loads

- Edge connectors allow simulation of real hot swap events

- External signals can be switched in through SMB connectors to override V_{IN} , $SENSE$, and UV/OV signals

- Opto-isolators for logic inputs and outputs

Micro evaluation board feature:

- Drops into a user's system, replacing the current hot swap device

MAIN EVALUATION KIT CONTENTS

- Main evaluation board

- Micro evaluation board

- ADM1073 data sheet

- EVAL-ADM1073EB evaluation kit data sheet

- 5 ADM1073 samples

MICRO EVALUATION KIT CONTENTS

- Micro evaluation board

- ADM1073 data sheet

- EVAL-ADM1073EB evaluation kit data sheet

- 5 ADM1073 samples

GENERAL DESCRIPTION

This evaluation kit allows the ADM1073 negative-voltage hot swap controller to be easily evaluated. The ADM1073 provides undervoltage and overvoltage protection by monitoring the supply voltage, and robust current limiting by monitoring the load current. The device uses a FET in the power path to control the load current.

MAIN EVALUATION BOARD FUNCTIONAL BLOCK DIAGRAM

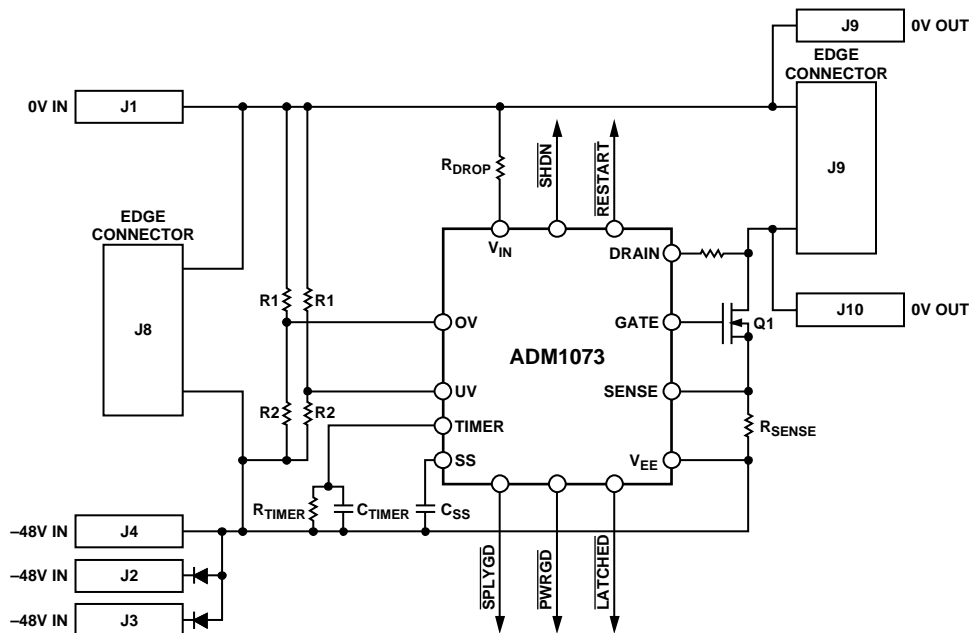

Figure 1.

045822-0-001

Rev. 0

Information furnished by Analog Devices is believed to be accurate and reliable. However, no responsibility is assumed by Analog Devices for its use, nor for any infringements of patents or other rights of third parties that may result from its use. Specifications subject to change without notice. No license is granted by implication or otherwise under any patent or patent rights of Analog Devices. Trademarks and registered trademarks are the property of their respective owners.

TABLE OF CONTENTS

Evaluation Board Hardware.....	3	Operating the Micro Evaluation Board.....	11
Important.....	3	Setting up the Micro Evaluation Board.....	11
Connector, Switch, Jumper, and LED Functions	3	Integrating the Micro Evaluation Board into the System	12
Operating the Main Evaluation Board	8	Evaluation Board Schematics.....	13
ADM1073 Residing on a Plug-In Board	8	Ordering Information.....	16
ADM1073 Residing on a Backplane	9	Main Evaluation Board Bill of Materials.....	16
Load Board.....	9	Micro Evaluation Board Bill of Materials	17
Backplane Board.....	9	Ordering Guide	18
Setting up the Main Evaluation Board	10		

REVISION HISTORY

9/04—Revision 0: Initial Version

EVALUATION BOARD HARDWARE

IMPORTANT

Take the following precautions, when using the EVAL-ADM1073EB evaluation kit under high voltage conditions:

- Do not work alone.
- Always keep one hand in your pocket or behind your back when around a high voltage system.
- Wear footwear with a rubber bottom.
- Wear eye protection (safety goggles).
- Do not wear any jewelry or other articles that could accidentally contact circuitry and conduct current.
- Work on an antistatic mat.
- Set up your work area away from possible grounds that you might accidentally contact.
- Connect/disconnect any test leads with the power off and the equipment unplugged. Use clip leads or solder temporary wires to reach difficult-to-access locations.
- Perform as many tests as possible with the power off and the equipment unplugged.
- After tests have been performed with the power applied, turn off the power and disconnect the power supply from the board.
- Fully discharge large load capacitors with an appropriate resistor.

CONNECTOR, SWITCH, JUMPER, AND LED FUNCTIONS

Table 1. Connector Functions

Pin	Name	Function
J1	–48VRTN	Black Banana Connector. –48 V return input voltage line.
J2	–48VIN	Blue Banana Connector. –48 V input voltage line.
J3	–48VIN	Blue Banana Connector. –48 V input voltage line (diode OR'ed with J4 input).
J4	–48VIN	Blue Banana Connector. –48 V input voltage line (diode OR'ed with J3 input).
J5	V _{IN}	SMB Connector. V _{IN} voltage can be monitored via J5.
J6	–48VOUT	Blue Banana Connector. –48 V output voltage line.
J7	UV	SMB Connector. UV voltage can be monitored or applied via J5.
J8		Edge Connector. Allows connection of a backplane board for powering the board and simulating hot swap events.
J9		Edge Connector. Allows connection of a load board for simulating hot swap events.
J10	–48VRTN	Black Banana Connector. –48 V return output voltage line.
J11	OV	SMB Connector. OV voltage can be monitored or applied via J11.
J12		$\overline{\text{SPLYGD}}$, $\overline{\text{PWRGD}}$, and $\overline{\text{LATCHED}}$ outputs can monitored via J12. J12-1: Feed $\overline{\text{SPLYGD}}$ to J12-1 by closing S7-3 switch. J12-2: Feed $\overline{\text{PWRGD}}$ to J12-2 by closing S7-6 switch. J12-3: Feed $\overline{\text{LATCHED}}$ to J12-3 by closing S7-9 switch.
J13		$\overline{\text{SHDN}}$ and $\overline{\text{RESTART}}$ inputs can be applied or monitored via J13. J13-1: Feed $\overline{\text{SHDN}}$ to J13-1 by closing S5-6 switch. J13-2: Feed $\overline{\text{RESTART}}$ to J13-2 by closing S5-2 switch.
J14		Allows an external voltage to be applied to overdrive the SS pin. This alters the internal current limit reference voltage, which, in effect, alters the current limit level. J14-1: Applies SS voltage to this terminal. J14-2: ADM1073 V _{EE} voltage.

EVAL-ADM1073EB

Table 2. Switch Functions

Switch	Description	Position	Function	Default
S1	Pushbutton switch for driving $\overline{\text{RESTART}}$ pin (via S5-1)	N/A	Active-low pulse sent to pin when button is depressed	N/A
S2	Pushbutton switch for driving $\overline{\text{SHDN}}$ pin (via S5-5)	N/A	Active-low pulse sent to pin when button is depressed	N/A
S3				
S3-1	Connects R18 to V_{IN} pin	Closed	Base of FET Q2 connected to V_{IN} pin	Open
S3-2	Connects R17 to V_{IN} pin	Open	Base of FET Q2 unconnected	Open
S3-3	Connects $\overline{\text{PWRGD}}$ pin to links L6 and L7	Closed	Emitter of FET Q2 connected to V_{IN} pin	Open
S3-4	Unused	Open	Emitter of FET Q2 unconnected $\overline{\text{PWRGD}}$ pin connected to L6, L7 $\overline{\text{PWRGD}}$ pin not connected to U5	Open
S4				
S4-1	Connects midpoint of R1/R2 resistor divider to OV pin	Closed	R1/R2 node connected to OV pin	Closed
S4-2	Connects R1/R2/R3 resistor network to OV pin	Open	R1/R2 node disconnected	Open
S4-3	Connects J11 to OV pin	Closed	R1/R2/R3 node connected to OV pin	Open
S4-4	Connects midpoint of R1/R2 resistor divider to UV pin	Open	R1/R2/R3 node disconnected	Open
S4-5	Connects R1/R2/R3 resistor network to UV pin	Closed	J11 connected to OV pin	Open
S4-6	Connects J11 to OV pin	Open	J11 disconnected	Closed
S4-7		Closed	R1/R2 node connected to UV pin	Closed
S4-8		Open	R1/R2 node disconnected	Open
S4-9		Closed	R1/R2/R3 node connected to OV pin	Open
S4-10		Open	R1/R2/R3 node disconnected	Open
S4-11		Closed	J11 connected to OV pin	Open
S4-12		Open	J11 disconnected	Open
S5				
S5-1	Connects LED D3 to $\overline{\text{RESTART}}$ pin	Closed	D3 connected to $\overline{\text{RESTART}}$ pin	Closed
S5-2	Connects pushbutton switch S1 to $\overline{\text{RESTART}}$ pin	Open	D3 disconnected	Closed
S5-3	Connects J13-2 to the $\overline{\text{RESTART}}$ pin	Closed	S1 connected to $\overline{\text{RESTART}}$ pin	Closed
S5-4	Connects opto-isolator U2 to $\overline{\text{RESTART}}$ pin	Open	S1 disconnected	Open
S5-5	Connects $\overline{\text{LATCHED}}$ output to $\overline{\text{RESTART}}$ input	Closed	J13 connected to $\overline{\text{RESTART}}$ pin	Open
S5-6	Connects LED D4 to $\overline{\text{SHDN}}$ pin	Open	J13 disconnected	Open
S5-7	Connects pushbutton switch S2 to $\overline{\text{SHDN}}$ pin	Closed	U2 connected to $\overline{\text{RESTART}}$ pin	Open
S5-8	Connects J13-1 to $\overline{\text{SHDN}}$ pin	Open	U2 disconnected	Open
S5-9	Connects opto-isolator U3 to $\overline{\text{SHDN}}$ pin	Closed	Both pins connected	Open
S5-10	Connects $\overline{\text{LATCHED}}$ output to $\overline{\text{SHDN}}$ input	Open	Both pins disconnected	Open
S5-11		Closed	D4 connected to $\overline{\text{SHDN}}$ pin	Closed
S5-12		Open	D4 disconnected	Closed
S5-13		Closed	S1 connected to $\overline{\text{SHDN}}$ pin	Closed
S5-14		Open	S1 disconnected	Closed
S5-15		Closed	J13 connected to $\overline{\text{SHDN}}$ pin	Open
S5-16		Open	J13 disconnected	Open
S5-17		Closed	U2 connected to $\overline{\text{SHDN}}$ pin	Open
S5-18		Open	U2 disconnected	Open
S5-19		Closed	Both pins connected	Open
S5-20		Open	Both pins disconnected	Open

Switch	Description	Position	Function	Default
S6				
S6-1	Connects user TIMER capacitor (C6) to TIMER pin	Closed Open	C6 connected to TIMER pin C6 disconnected pin	Open
S6-2	Connects default TIMER capacitor (C7) to TIMER pin	Closed Open	C7 connected to TIMER pin C7 disconnected pin	Closed
S6-3	Connects large TIMER capacitor (C8) to TIMER pin	Closed Open	C8 connected to TIMER pin C8 disconnected pin	Open
S6-4	Connects small TIMER capacitor (C9) to TIMER pin	Closed Open	C9 connected to TIMER pin C9 disconnected pin	Open
S6-5	Connects small TIMER resistor (R23) to TIMER pin	Closed Open	R23 connected to TIMER pin R23 disconnected	Open
S6-6	Connects large TIMER resistor (R22) to TIMER pin	Closed Open	R22 connected to TIMER pin R22 disconnected	Open
S6-7	Connects default TIMER resistor (R21) to TIMER pin	Closed Open	R21 connected to TIMER pin R21 disconnected	Open
S6-8	Connects user TIMER resistor (R20) to TIMER pin	Closed Open	R20 connected to TIMER pin R20 disconnected	Open
S7				
S7-1	Connects LED D5 to $\overline{\text{SPLYGD}}$ pin	Closed Open	LED D5 enabled LED D5 disabled	Closed
S7-2	Connects opto-isolator U4 to $\overline{\text{SPLYGD}}$ pin	Closed Open	U4 connected to $\overline{\text{SPLYGD}}$ pin U4 disconnected	Open
S7-3	Connects J12-1 to $\overline{\text{SPLYGD}}$ pin	Closed Open	J12 connected to $\overline{\text{SPLYGD}}$ pin J12 disconnected	Open
S7-4	Connects LED D6 to $\overline{\text{PWRGD}}$ pin	Closed Open	LED D6 enabled LED D6 disabled	Closed
S7-5	Connects opto-isolator U5 to $\overline{\text{PWRGD}}$ pin	Closed Open	U5 connected to $\overline{\text{PWRGD}}$ pin U5 disconnected	Open
S7-6	Connects J12-2 to $\overline{\text{PWRGD}}$ pin	Closed Open	J12 connected to $\overline{\text{PWRGD}}$ pin J12 disconnected	Open
S7-7	Connects LED D7 to $\overline{\text{LATCHED}}$ pin	Closed Open	LED D7 enabled LED D7 disabled	Closed
S7-8	Connects opto-isolator U6 to $\overline{\text{LATCHED}}$ pin	Closed Open	U6 connected to $\overline{\text{LATCHED}}$ pin U6 disconnected	Open
S7-9	Connects J12-3 to $\overline{\text{LATCHED}}$ pin	Closed Open	J12 connected to $\overline{\text{LATCHED}}$ pin J12 disconnected	Open
S7-10	Not connected	N/A	N/A	N/A
S8				
S8-1	Connects small SS capacitor (C4) to SS pin	Closed Open	C4 connected to SS pin C4 disconnected	Open
S8-2	Connects large SS capacitor (C3) to SS pin	Closed Open	C3 connected to SS pin C3 disconnected	Open
S8-3	Connects default SS capacitor (C2) to SS pin	Closed Open	C2 connected to SS pin C2 disconnected	Closed
S8-4	Connects user SS capacitor (C1) to SS pin	Closed Open	C1 connected to SS pin C1 disconnected	Open

EVAL-ADM1073EB

Table 3. Jumper Functions

Switch	Description	Default In/Out
L1		
L1-A	Connects R13 to V _{IN} pin	Out
L1-A	Connects R14 to V _{IN} pin	Out
L1-A	Connects R15 to V _{IN} pin	Out
L1-A	Connects R16 to V _{IN} pin	Out
L2	Connects R12 to V _{IN} pin	In
L3	Connects driver circuit for all LEDs	In
L4		
L4-A	Connects R11 to DRAIN pin	In
L4-A	Connects R10 to DRAIN pin	Out
L5		
L5-A	Connects Pin 1 of U5 to external circuit	Out
L5-A	Connects Pin 1 of U5 to patchwork	In
L6		
L6-A	Connects Pin 6 of U5 to external circuit	Out
L6-A	Connects Pin 6 of U5 to patchwork	In
L7		
L7-A	Connects Pin 5 of U5 to external circuit	Out
L7-A	Connects Pin 5 of U5 to patchwork	In

Table 4. LED Functions

LED	Name	Function
D3	RESTART	Indicates when an active-low pulse is asserted on the $\overline{\text{RESTART}}$ input. This yellow LED turns on when the line is driven low, indicating that a soft reset event has been initiated. Use Switch S5 to set different methods of driving $\overline{\text{RESTART}}$. Note: S13-1 must be closed to enable this LED.
D4	$\overline{\text{SHDN}}$	Indicates when an active-low pulse is asserted on the $\overline{\text{SHDN}}$ input. This yellow LED is on when the line is driven low, indicating that a reset event has been initiated. Use Switch S5 to set different methods of driving $\overline{\text{SHDN}}$. Note: S13-6 must be closed to enable this LED.
D5	$\overline{\text{SPLYGD}}$	Indicates when the active-low $\overline{\text{SPLYGD}}$ output is asserted. This green LED turns on when the line is driven low, indicating that the supply voltage is inside the programmed operating range. Note: S7-1 must be closed to enable this LED.
D6	$\overline{\text{PWRGD}}$	Indicates when the active-low $\overline{\text{PWRGD}}$ output is asserted. This green LED turns on when the line is driven low, indicating that the load capacitance has been fully charged and the output voltage is at its full potential. Note: S7-4 must be closed to enable this LED.
D7	$\overline{\text{LATCHED}}$	Indicates when the active-low $\overline{\text{LATCHED}}$ output is asserted. This red LED turns on when the line is driven low, indicating that a current fault has caused the ADM1073 to latch off. Note: S7-7 must be closed to enable this LED.

Table 5. Testpoints

Testpoint	Function
T1	Monitors the -48VRTN line. This voltage is typically 48 V above the -48VIN rail and V_{EE} . This line can be considered an input and output line.
T2	Monitors the voltage on the ADM1073 OV (overvoltage) pin.
T3	Monitors the voltage on the ADM1073 UV (undervoltage) pin.
T4	Monitors the -48 V input line. This voltage is tied to ADM1073 ground (V_{EE} pin).
T5	Monitors the -48 V input line. This voltage is tied to ADM1073 ground (V_{EE} pin).
T6	Monitors the V_{IN} pin. This voltage is typically 12 V above the -48VIN rail and V_{EE} .
T7	Monitors the GATE pin. This voltage is 12 V under normal operating conditions.
T8	Monitors the DRAIN pin, which is used for linear current foldback.
T9	Monitors the TIMER pin, which is used to control the on-time of the retry function.
T10	Monitors the SS pin, which is used to control the soft start ramp rate.
T11	Monitors the -48VRTN line. This voltage is typically 48 V above the -48VIN rail and V_{EE} . This line can be considered an input and output line.
T12	Monitors the -48 V output line. This node is also connected to the FET DRAIN pin and DRAIN resistor.
T13	Monitors the -48 V input voltage/ADM1073 V_{EE} voltage close to the SENSE resistor. The V_{EE} to SENSE voltage is the voltage across the sense resistor. A probe across T13 and T14 gives an accurate measurement of the voltage across the sense resistor.
T14	Monitors the SENSE voltage. The V_{EE} to SENSE voltage is the voltage across the SENSE resistor. This node is also the source pin of the pass FET. A probe across T13 and T14 gives an accurate measurement of the voltage across the SENSE resistor.
T15	Monitors the voltage on the $\overline{\text{FET source}}$ voltage.
T16	Monitors the voltage on the $\overline{\text{LATCHED}}$ input.
T17	Monitors the voltage on the $\overline{\text{PWRGD}}$ input.
T18	Monitors the voltage on the $\overline{\text{SPLYGD}}$ input.

OPERATING THE MAIN EVALUATION BOARD

Many tests and hot swap scenarios can be modeled on the EVAL-ADM1073EB main evaluation board:

- Powering up into a load (resistive, capacitive, RC combination); successful hot swap
- Powering up, then applying a load (resistive, capacitive, RC combination); successful hot swap
- Powering up into a shorted output
- Powering up, then shorting the output
- Permanent overcurrent fault
- Temporary overcurrent fault
- Temporary overcurrent fault followed by a permanent overcurrent fault
- Three distinct levels of overcurrent fault (see the ADM1073 data sheet)
- Overvoltage condition
- Undervoltage condition

All tests involving shorts can be simulated with the ADM1073 residing on either the plug-in module/board side or the backplane side. The main evaluation board can be configured to recreate the two ways in which the ADM1073 can be used in a real system.

ADM1073 RESIDING ON A PLUG-IN BOARD

Typically, the ADM1073 and its accompanying components are mounted on a plug-in board. This board is then slotted into the live backplane, when required. When the power lines connect, the ADM1073 powers up. If the supply is stable and within tolerance, it turns the FET on in a controlled manner, applying power safely to the load and powering up the rest of the board.

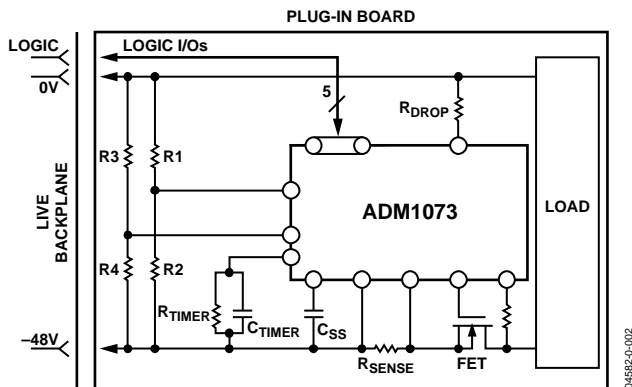

Figure 2. ADM1073 Residing on a Plug-In Module

To evaluate the ADM1073 residing on a plug-in board, set up the evaluation board as follows:

1. Set up the board with the preferred load. You can connect the load to the board in several ways:
 - If a single load component is sufficient, you can solder the component directly onto the evaluation board in the C4 position.
 - You can custom-build a board to simulate a plug-in module's load and plug it into Edge Connector J9. (See Figure 8 for a schematic of the J9 pin diagram.)
 - Connect a load via Connectors J6 and J10.
 - If a no-load condition is required, do not connect anything to J6, J9, or J10, and do not solder any additional load components to the evaluation board.

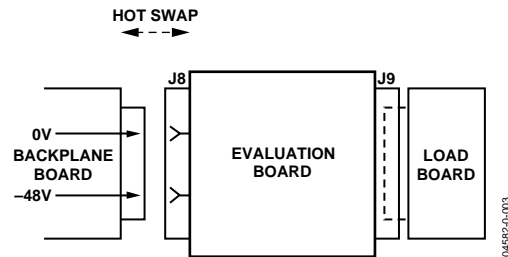

Figure 3. Evaluation Board Simulating the Setup in Figure 1

2. Apply power to the board via leads connected directly to a power supply. Power is normally applied through the black and blue banana connectors (J1 to J4). Connect the higher potential (RTN or 0 V) to Socket J1 (black). Connect the lower potential of the supply to J2 or J3 (blue). A diode OR'ing scheme is employed at these terminals, so that two supplies can be applied simultaneously, if required. In this situation, the supply with the higher potential is used. If this supply potential drops below the voltage of the second redundant supply, then the board switches over to the second supply. To bypass the diodes, connect a single power supply to the board via Socket J2 (blue).
3. To recreate a live insertion event, either turn on the power supply or make the connection to the live supply. Take the proper safety precautions when applying live voltages to the evaluation board.

- You can also apply power to the board via Connector J8. A simple backplane board can be constructed that plugs into Connector J8 and provides the -48 V supply. You can now simulate a live insertion event by plugging the backplane board (see the Backplane Board section) with a live negative supply into Connector J8.
- To simulate a reseating event, disconnect the evaluation board and backplane boards and reconnect them while the supply is live. This corresponds to manually reseating a plug-in module. This method recreates a board insertion and/or removal scenario more accurately, because the plugging or unplugging of a board from a live supply triggers the ADM1073 to respond. Again, take the proper precautions when connecting live voltages to the evaluation board.

ADM1073 RESIDING ON A BACKPLANE

The ADM1073 can perform similar undervoltage and overvoltage protection and current limiting functions when placed on the backplane itself.

This type of setup can be recreated with the ADM1073 evaluation board. Power can be applied through a backplane board or with power leads, as described in the ADM1073 Residing on a Plug-In Board section. The power supply and the evaluation board should be connected together by either method, and the power applied (Figure 4). This unit now represents a live backplane with built-in ADM1073 circuitry in Figure 5.

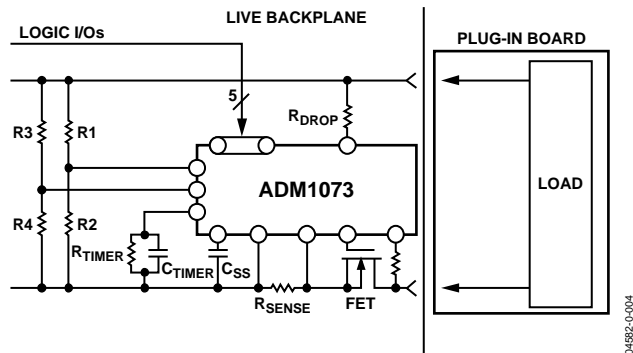

Figure 4. ADM1073 Residing on a Backplane

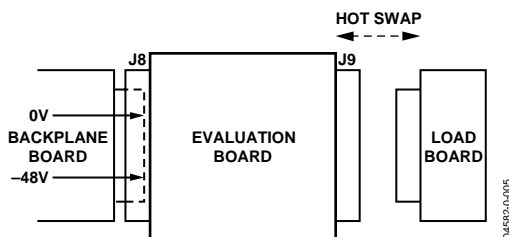

Figure 5. Evaluation Board Simulating the Setup in Figure 3

To simulate a live insertion event with the ADM1073 residing on the backplane:

- Connect the load to the evaluation board via Connector J9, or J9 and J10, as described in the ADM1073 Residing on a Plug-In Board section.
- To represent reseating, disconnect and reconnect the load from/to the evaluation board.

Note that the ADM1073 can be employed on both the plug-in board/module and the backplane sides of a system. This provides the system with double protection.

LOAD BOARD

Figure 6 is a diagram of a load board that emulates the load on a plug-in module and connects to Connector J9. This board contains a series resistance and capacitance connected in parallel. A set of jumpers changes the manner in which the components are applied: resistor only, capacitor only, RC in parallel, or short circuit. The board should be set up via the jumpers before power is applied. For example, to set up the load board to emulate an RC load, place shorting links into both LK1 A and LK1 B jumpers, and leave LK2 open.

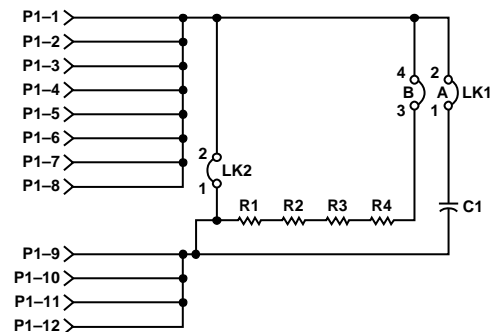

Figure 6. Diagram of Load Board

BACKPLANE BOARD

You can also employ a backplane board to emulate the backplane side of your system. This board provides an alternative way of applying power to the ADM1073 evaluation board (instead of using the J1 to J4 power connectors of the evaluation board).

- Insert the backplane board into Edge Connector J8 of the evaluation board to apply power to the board. This might be useful when simulating live insertion and removal events with the ADM1073 evaluation kit, especially when simulating a situation where the ADM1073 resides on a plug-in module.
- To recreate a live insertion event, plug the backplane board (with a live supply) into the evaluation board (Connector J8).

EVAL-ADM1073EB

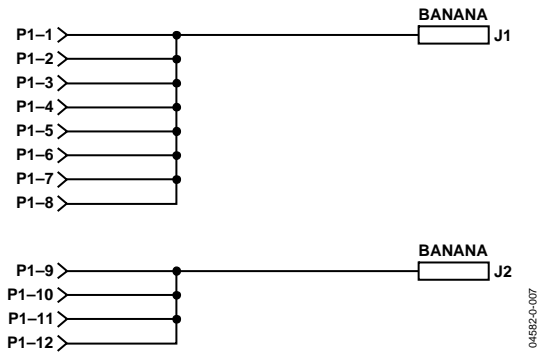

Figure 7. Diagram of Backplane Board

SETTING UP THE MAIN EVALUATION BOARD

The evaluation board can have different configurations of supply voltage, operating range, maximum allowable load current, and timing values.

To set up the main evaluation board:

1. Choose a shunt resistor. A constant voltage of 12.3 V (above V_{EE}) is generated at the V_{IN} pin via the shunt resistor. A shorting link in Header L2 selects the standard R_{DROP} of 20 k Ω . Other resistors and resistor combinations can be selected via header L1. The V_{IN} voltage can be monitored via Connector J5.
2. Choose values for Resistors R1 to R4 to suit the desired operating voltage range and hysteresis levels. The default resistors values ($R1/R3 = 39$ k Ω , $R2/R4 = 1$ k Ω) give an operating range of ~ 34.5 V to ~ 78 V with hysteresis levels of ~ 200 mV on UV and OV. You can also use a 3-resistor string (R5 to R7) to set these parameters. Use Switch S4 to apply the preferred network. See the ADM1073 data sheet for other resistor ratios and their operating ranges. Note that 1% accurate resistors should be used for accuracy.
3. Choose the maximum load current that is permitted before the ADM1073 registers a current fault. This is determined by the choice of sense resistor, R_{SENSE} (R6). The evaluation board has a 33 m Ω sense resistor by default, which sets up a maximum inrush current level of 3.12 A and maximum load current level of 2.61 A. R_{SENSE} can be changed to alter the load current level (see the ADM1073 datasheet for details). Note that 1% accurate resistors should be used for accuracy.
4. Choose a value for the soft start capacitor, C_{SS} . This capacitor is connected between the SS pin and V_{EE} . It adjusts the soft start current profile at initial connection. You can switch in different capacitor values via Switch S8 on the evaluation board. See the ADM1073 datasheet for details.
5. Choose values for the TIMER capacitor, C_{TIMER} , and the TIMER resistor, R_{TIMER} . These components set the on-time of the limited consecutive retry scheme. You can switch in different capacitor and resistor values via Switch S6 on the evaluation board. See the ADM1073 datasheet for details.
6. Choose the value of the drain resistor required for linear limit foldback via a shorting link in Header L4. The default value of 2.2 M Ω is selected by a shorting link in Header L4, Position B.
7. The evaluation board has an IRF3910 DPAK FET mounted by default. If you want to change this FET, remove the component Q1, and mount a replacement. Note that a triple footprint is present that can accommodate DPAK, D2PAK, and many through-hole FET packages.

OPERATING THE MICRO EVALUATION BOARD

The EVAL-ADM1073EB evaluation kit contains a second evaluation board, the EVAL-ADM1073EB micro evaluation board, which is designed to drop onto a plug-in module or a backplane, replacing the current hot swap device. The performance of the ADM1073 can then be evaluated within your system.

The micro evaluation board contains a subset of the main evaluation board components :

- On-board FET to control load current
- Programmable operating voltage range (R1 to R4)
- Programmable current limit levels (value of R_{SENSE})
- Programmable soft start ramp (Capacitor C_{SS})
- Programmable TIMER on-time
- LEDs on all logic I/Os
- Pushbutton switches for asserting logic inputs

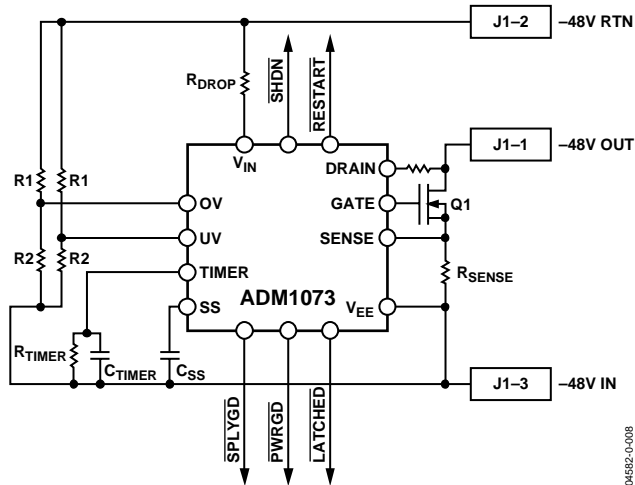

Figure 8. Micro Evaluation Board Functional Block Diagram

By cutting various tracks around the current hot swap device in a user system and soldering the ADM1073 micro evaluation board in position above it, the ADM1073 and its external components can be integrated into the system in place of the original hot swap circuitry. This allows the user to evaluate the ADM1073's performance in the system itself.

SETTING UP THE MICRO EVALUATION BOARD

You can set up the micro evaluation board in various configurations, as follows:

1. Choose a shunt resistor. A default R_{DROP} of 20 k Ω is mounted on the micro evaluation board. A constant voltage of 12.3 V (above V_{EE}) is generated at the V_{IN} pin.
2. Choose values for Resistors R1 to R4 to suit the desired operating voltage range and hysteresis levels. The default resistors values ($R1/R3 = 39$ k Ω , $R2/R4 = 1$ k Ω) give an operating range of ~34.5 V to ~78 V with hysteresis levels of ~200 mV on UV and OV. See the ADM1073 data sheet for other resistor ratios and their operating ranges. Note that 1% accurate resistors should be used for accuracy.
3. Choose the maximum load current that is permitted before the ADM1073 registers a current fault. This is determined by the choice of sense resistor, R_{SENSE} (R6). The evaluation board has a 33 m Ω sense resistor by default, which sets up a maximum inrush current level of 3.12 A and maximum load current level of 2.61 A. R_{SENSE} can be changed to alter the load current level. See the ADM1073 datasheet for details. Note that 1% accurate resistors should be used for accuracy.
4. Choose a value for the soft start capacitor, C_{SS} . This capacitor is connected between the SS pin and V_{EE} . It adjusts the soft start current profile at initial connection. Different value capacitors can be soldered in. See the ADM1073 data sheet for details.
5. Choose values for the TIMER capacitor, C_{TIMER} , and the TIMER resistor, R_{TIMER} . These components set the on-time of the limited consecutive retry scheme. Different capacitor and resistor values can be soldered. See the ADM1073 data sheet for details.
6. Choose the value of the drain resistor required for linear limit foldback via a shorting link in Header L4. A default value of 2.2 M Ω is mounted on the micro evaluation board, but you can alter this component, if required.
7. The micro evaluation board has an IRF3910 DPAK FET mounted by default. If you want to change this FET, remove the component, Q1, and mount a replacement. Note that a dual footprint is present on the micro evaluation board that can accommodate DPAK and D2PAK packages.

INTEGRATING THE MICRO EVALUATION BOARD INTO THE SYSTEM

The current system must be modified to disconnect or remove the existing hot swap circuitry and replace it with the micro evaluation board. The following steps describe a situation in which the hot swap circuitry resides on a plug-in module. The same method applies when a backplane-side hot swap system is implemented.

1. Locate the existing hot swap device and its accompanying components and disconnect this portion of the system by cutting the relevant tracks on the board, or alternatively, desoldering and removing the relevant components, as shown in Figure 9.

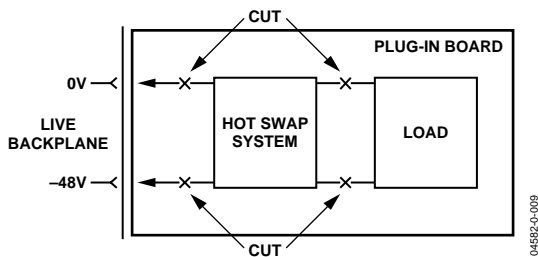

Figure 9. Removing Existing Hot Swap Circuitry from the System

2. To integrate the micro evaluation board into your system in place of the original hot swap circuitry, clamp three wires into the terminal block, J1, of the micro evaluation board and solder them into position on the board. If you need to access the logic I/Os, there are blank pads on the board that can be used for this purpose. The micro evaluation board now substitutes for the old hot swap circuitry, as shown in Figure 10.

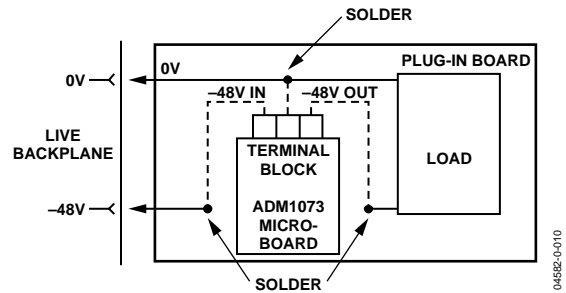

Figure 10. Integrating the Micro Evaluation Board into the System

The micro evaluation board has an insulating coating on its underside to protect the system. If the underside of the board were not protected, shorts could occur on the module or backplane below it.

EVALUATION BOARD SCHEMATICS

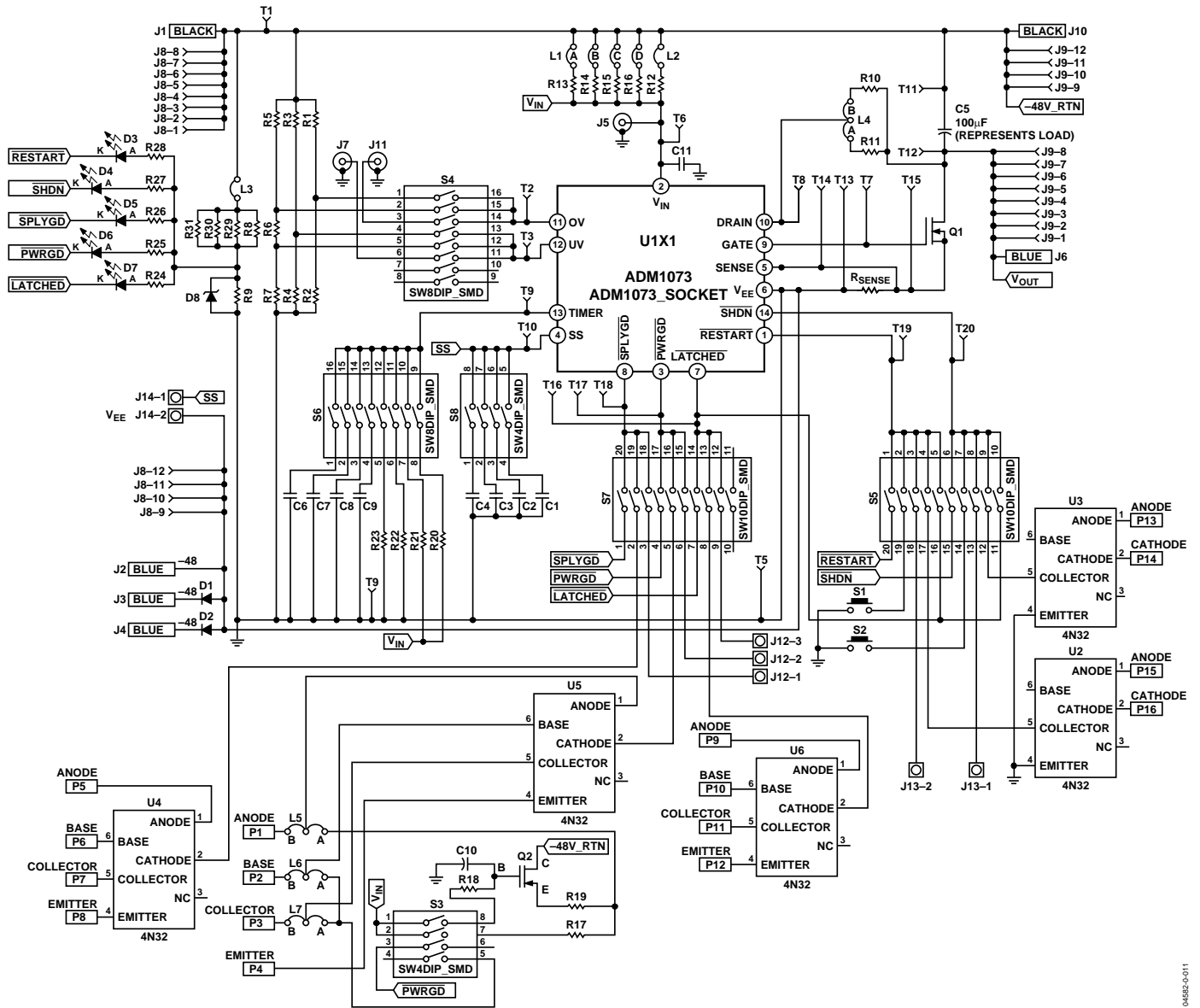
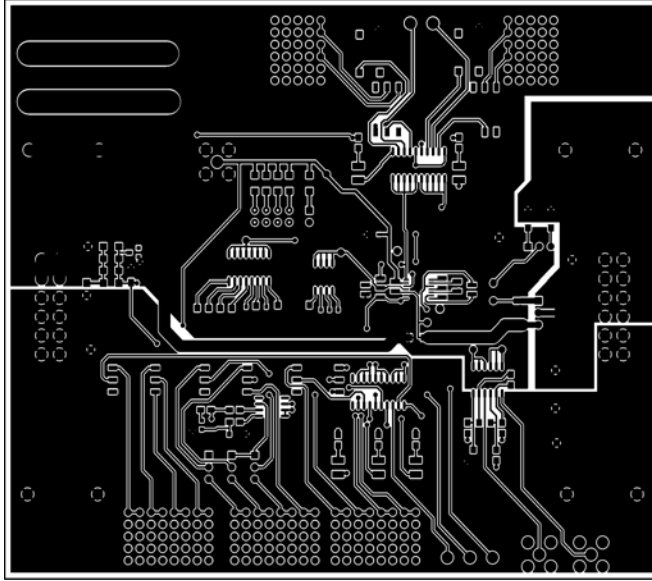

Figure 11. EVAL-ADM1073EB Evaluation Board Schematic

04952-0-011



04582-0-012

Figure 12. EVAL-ADM1073EB Evaluation Board Component-Side Silkscreen

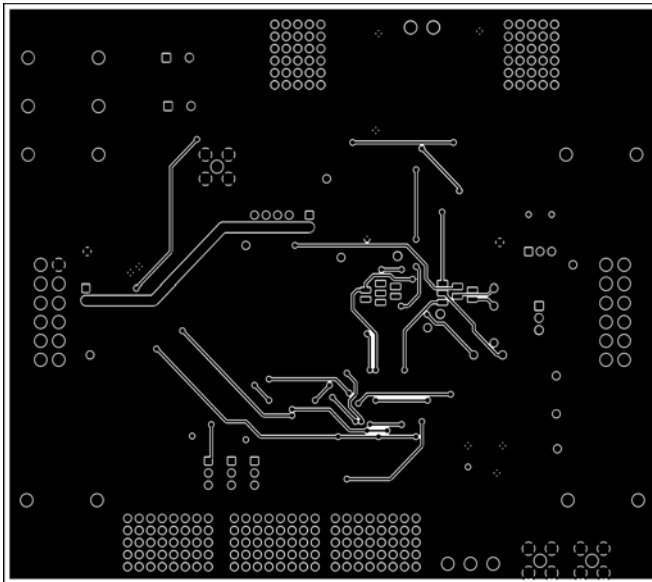

04582-0-013

Figure 13. EVAL-ADM1073EB Evaluation Board Solder-Side Silkscreen

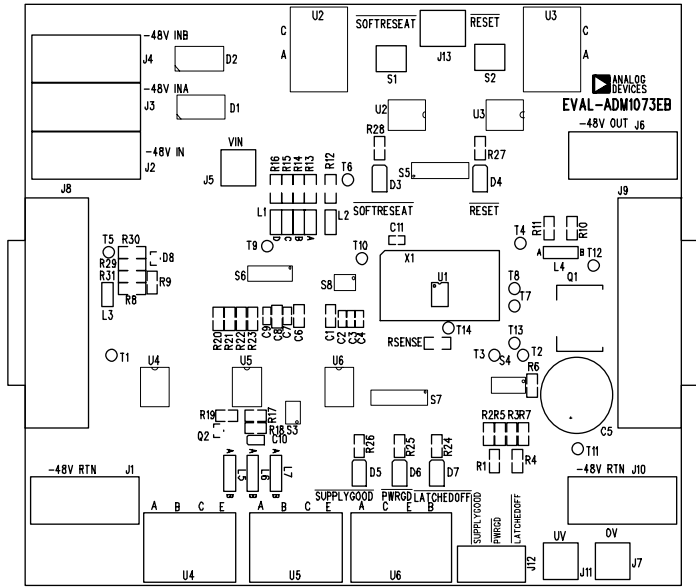

Figure 14. EVAL-ADM1073EB Evaluation Board Component Placement Diagram

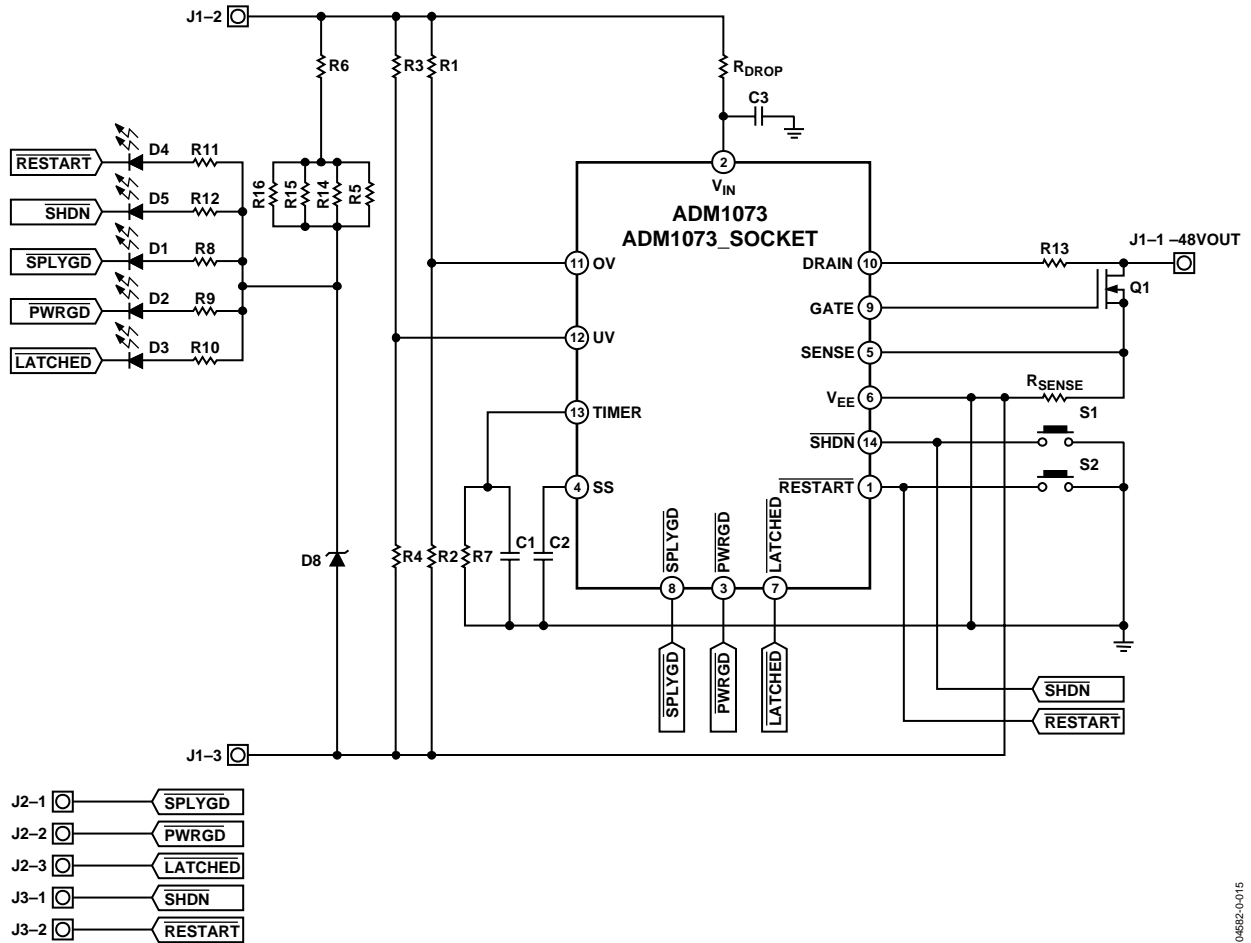

Figure 15. EVAL-ADM1073EB Micro Evaluation Board Circuit Diagram

EVAL-ADM1073EB

ORDERING INFORMATION

MAIN EVALUATION BOARD BILL OF MATERIALS

Table 6.

Qty	Ref Description	Part Type	Value	Part Decal	Part No.
1	X1	ADM1073_SKT		14-TSSOP SKT	OTS14(24)-0.65-01
1	U1	ADM1073ARU		14-TSSOP	ADM1073
5	U2–U6	4N32		DIP6_SMD	FEC 359-7830
1	C1	CAP	N/A	0805	N/A
1	C2	CAP (C _{SS} nom)	0.82 nF	0603	FEC 301-9652
1	C3	CAP(C _{SS} max)	8.2 nF	0603	FEC 301-9718
1	C4	CAP (C _{SS} min)	0.1 nF	0603	FEC 722-110
1	C5	CAP+	100 µF	CAP_ELEK_8MM	FEC 319-9204
1	C6	CAP	N/A	805	N/A
1	C7	CAP (C _{TIMER} typ)	82 nF	603	FEC 301-9550
1	C8	CAP (C _{TIMER} max)	690 nF	805	FEC 335-2055
1	C9	CAP (C _{TIMER} min)	6.8 nF	603	FEC 722-224
1	C10	CAP	1 µF	805	
1	C11	CAP	0.1 µF	Taj-C	N/A FEC
2	R1, R3	RES	39 kΩ	805	912-049
4	R2, R4, R6, R7	RES	1 kΩ	805	FEC 911-859
1	R5	RES	82 kΩ	805	FEC 360-1950
1	R8	RES	1.8 kΩ	805	FEC 360-1754
1	R9	RES	N/A	805	
1	R10	RES (R _{DRAIN A})	2.2 MΩ	805	FEC360-2126
1	R11	RES (R _{DRAIN B})	10 MΩ	805	FEC 360-2205
1	R12	RES (R _{SHUNT NOM})	39 kΩ	1206	FEC 360-1158
1	R13	RES (R _{SHUNT B})	22 kΩ	1206	FEC 513-246
1	R14	RES	N/A	1206	
1	R15	RES	N/A	1206	
1	R16	RES	N/A	1206	
1	R17	RES	10 kΩ	805	FEC 360-1845
1	R18	RES	22 kΩ	805	FEC 360-1882
1	R19	RES	2.2 kΩ	805	FEC 360-1766
1	R20	RES (R _{TIMER} user)	N/A	805	
1	R21	RES (R _{TIMER} nom)	1.5 MΩ	805	FEC 360-2102
1	R22	RES (R _{TIMER} max)	15 MΩ	805	FEC 335-2481
1	R23	RES (R _{TIMER} min)	150 kΩ	805	FEC 360-1985
5	R24–R28	RES	470 Ω	805	FEC 196-230
1	RSENSE	RES	33 mΩ	1206	FEC 156-220
1	Q1	IRFR3910		DKPAK	FEC 706-486
1	Q2	SI2308DS		SOT23 3-PIN	FEC 334-5245
2	D1, D2	DIODE		DO35	FEC 505-950
2	D3, D4	LED		LED SMT Yellow	FEC 515-619
2	D5, D6	LED		LED SMT Green	FEC 515-620
1	D7	LED		LED SMT Red	FEC 515-607
1	D8	ZENER DIODE		SOT23 3-PIN	FEC 931-550
2	S1, S2	SW-PUSH-SMD		SW_PB_SMD_6MM	FEC 177-807
2	S3, S8	DIL SW 4WAY		DIL	FEC 312-680
1	S4	DIL SW 6WAY		DIL	FEC 312-691
2	S5, S6	DIL SW 8WAY		DIL	FEC 312-708
1	S7	DIL SW 10WAY		DIL	FEC 312-710

Qty	Ref Description	Part Type	Value	Part Decal	Part No.
2	J1, J10	BANANA		BANANA BLACK	FEC 150-040
4	J2-J4, J6	BANANA		BANANA BLUE	FEC 150-042
3	J5, J7, J11	SMB		SMB	FEC 310-682
2	J8, J9	CON\12P\ED\SKT		CON-12P-156-SRA	S5061-ND
1	J12	CON\PWR		3-way Term Block	FEC 151-786
1	J13	CON\PWR		2-way Term Block	FEC 151-785
14	T1-T14	TESTPOINT		TESTPOINT BLACK	FEC 240-333
1	L1	JUMPER-4		2 × 4-way Header	FEC 511-791
2	L2-L3	JUMPER		1 × 2-way Header	FEC 511-705
4	L4-L7	JUMPER2\SIP3		1 × 3-way Header	FEC 511-717
7	L1-L7	Shorting Links		Shorting Links	FEC 150-410
4	Each Corner	Stick-On Feet		3M	FEC 651-813

MICRO EVALUATION BOARD BILL OF MATERIALS

Table 7.

Qty	Ref Description	Part Type	Value	Part Decal	Part No.	Source
1	U1	ADM1073ARU		14-TSSOP	ADM1073	ADI
1	C1	CAP (C _{TIMER} nom)	82 nF	603	FEC 301-9550	FARNELL
1	C2	CAP (C _{SS} nom)	0.82 nF	0603	FEC 301-9652	FARNELL
1	C3	CAP	N/A	603	N/A	N/A
2	R1, R3	RES	39 kΩ	805	FEC 912-049	FARNELL
2	R2, R4	RES	1 kΩ	805	FEC 911-859	FARNELL
4	R5, R14, R15, R16	RES	8.2 kΩ	1206	FEC 360-1110	FARNELL
1	R6	RES	0 Ω	805	FEC 758-413	FARNELL
1	R7	RES (R _{TIMER} nom)	1.5 MΩ	805	FEC 360-2102	FARNELL
5	R8-R12	RES	470 Ω	805	FEC 196-230	FARNELL
1	R13	RES (R _{DRAIN})	10 MΩ	805	FEC 360-2205	FARNELL
1	RDROP	RES (R _{SHUNTNOM})	39 kΩ	1206	FEC 360-1158	FARNELL
1	RSENSE	RES	33 mΩ	1206	FEC 156-220	FARNELL
1	Q1	IRFR3910		DPAK	FEC 706-486	FARNELL
2	D3, D4	LED		LED SMT Yellow	FEC 515-619	FARNELL
2	D5, D6	LED		LED SMT Green	FEC 515-620	FARNELL
1	D7	LED		LED SMT Red	FEC 515-607	FARNELL
1	D8	ZENER DIODE		SOT23 3-PIN	FEC 931-550	FARNELL
2	S1, S2	SW-PUSH-SMD		Pushbutton Switch	FEC 535-930	FARNELL
1	J1	CON\PWR		3-way Term Block	FEC 151-786	FARNELL
1	J2	CON\PWR		3-way Term Block	N/A	FARNELL
1	J3	CON\PWR		2-way Term Block	N/A	FARNELL

EVAL-ADM1073EB

ORDERING GUIDE

Model	Package Description
EVAL-ADM1073EB	Main Evaluation Board and Micro Evaluation Board ¹
EVAL-ADM1073MEB	Micro Evaluation Board only

¹ Includes Main Evaluation Board for bench evaluation and Micro Evaluation Board for in-system evaluation.

NOTES

NOTES